

Small Capacity IH Cooker

(TYPE: IH-005, IH-007)



ITOH KOUKI CORPORATION

Machine Specifications

Type	IH-005	IH-007
IH Invertar Output	5kw	7kw
Electric Power	3Ph,200-220V 30A	3Ph,200-220V 40A
Required Power Capacity	6.0kVA	8.4kVA
Dimensions : A*B	750*800mm	850*940mm
Pan Dimensions	φ500*Depth170*33Liter	φ600*Depth170*50Liter
Pan Materials	Stainlass Steel 430	
Temperatue Control	PID Control (~300℃)	
Pan Inversion	Motor Drive Inversion(90°)	
Machine Weight	175kg	198kg

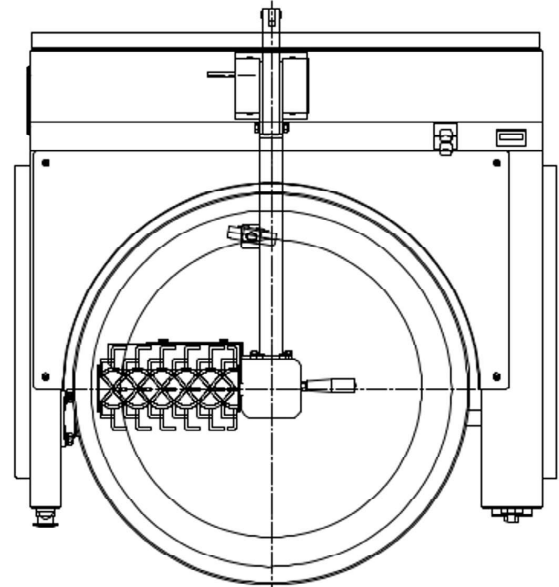

Dimensions : A

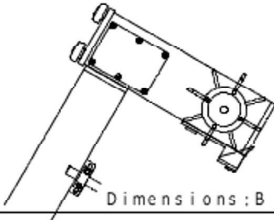
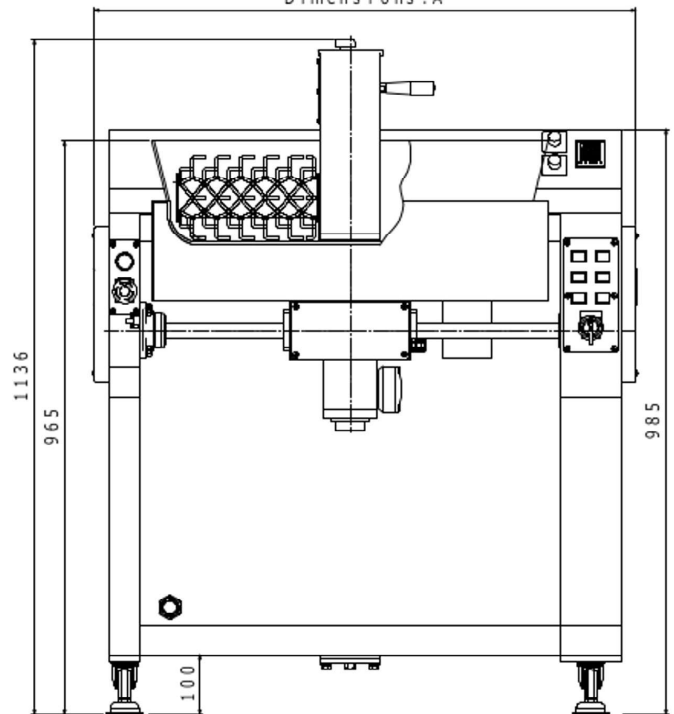

Dimensions : B

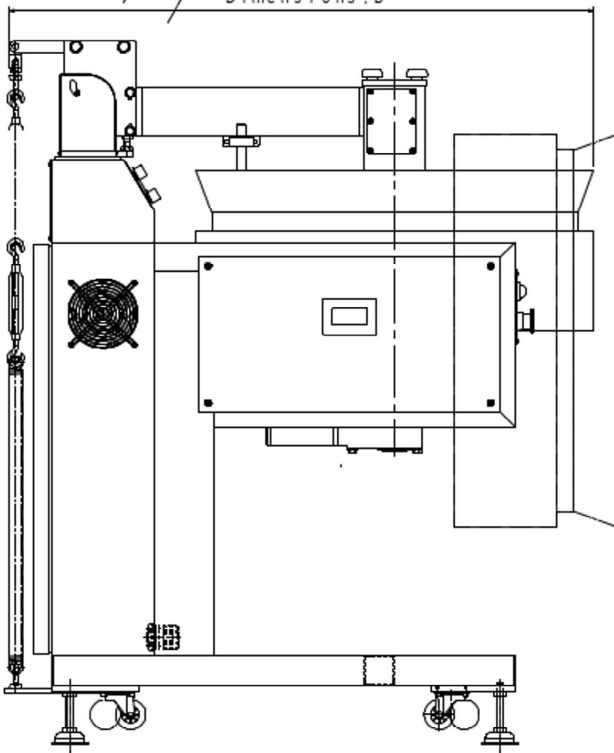

You can see the cooking video here.
(Read with your smartphone camera)



- I can cook the fried rice before ten in about 3 minutes.
- It is easily completed just to spend materials.
- I am finished by high output heating of the IH deliciously.
- Because I do not use the fire,I am safe.
- The part does not use the tool and can easily disintegrate.



IKC Asia-Pacific Pte Ltd.

15 Hindhede Place, Singapore 587864

Phone: +65 96567493

Email: henry.yee@ikcasiapac.com